

Physics Year 11 Term 3 Week 8

Circuit Analysis II

Circuit with different resistor values

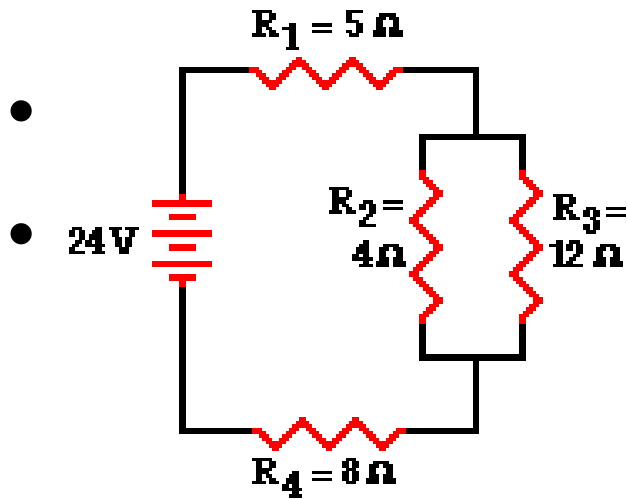

Simplify circuit

Replace 2 parallel resistors

$$1/R_{eq} = 1/R_1 + 1/R_2 + 1/R_3 \dots$$

$$1/R_{eq} = 1/(4\Omega) + 1/(12\Omega)$$

$$1/R_{eq} = 0.333\Omega^{-1}$$

$$R_{eq} = 1/(0.333\Omega^{-1})$$

$$R_{eq} = 3.00\Omega$$

Total Resistance



$$R_{\text{tot}} = R_1 + 3\ \Omega + R_4 = 5\ \Omega + 3\ \Omega + 8\ \Omega$$

$$R_{\text{tot}} = 16\ \Omega$$

Ohm's Law for I

- Ohm's law equation ($V = I \cdot R$)
- To determine the total I in the circuit.
- In doing so, the total resistance and the total voltage will have

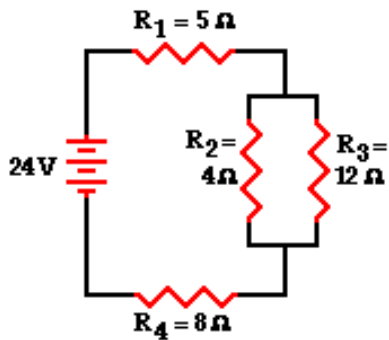

$$I_{\text{tot}} = \Delta V_{\text{tot}} / R_{\text{tot}} = (24\ \text{V}) / (16\ \Omega)$$
$$I_{\text{tot}} = 1.5\ \text{Amp}$$

- The 1.5 Amp current calculation represents the current at the battery location.
- Yet, resistors R_1 and R_4 are in series and the current in series-connected resistors is everywhere the same. Thus,

$$I_{\text{tot}} = I_1 = I_4 = 1.5\ \text{Amp}$$

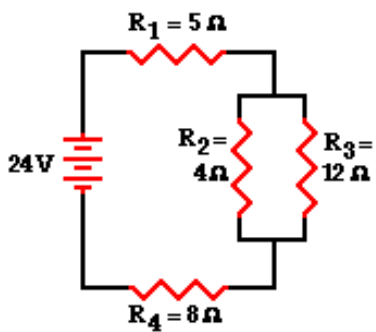

A Complication.....

- For parallel branches, the sum of the current in each individual branch is equal to the current outside the branches.
- Thus, $I_2 + I_3$ must equal 1.5 Amp.
- The unequal current in the two resistors complicates the analysis.
- The branch with the least resistance will have the greatest current.
- Determining the amount of current will demand that we use the Ohm's law equation.
- But to use it, the voltage drop across the branches must first be known.

Determining the Voltage Drop across the Parallel Branches

- Voltage drop across the 2 series-connected resistors (R_1 and R_4) must first be determined.
- The Ohm's law equation ($V = I \cdot R$) can be used to determine the voltage drop across each resistor.

$$\Delta V_1 = I_1 \cdot R_1 = (1.5 \text{ Amp}) \cdot (5 \Omega)$$

$$\Delta V_1 = 7.5 \text{ V}$$

$$\Delta V_4 = I_4 \cdot R_4 = (1.5 \text{ Amp}) \cdot (8 \Omega)$$

$$\Delta V_4 = 12 \text{ V}$$

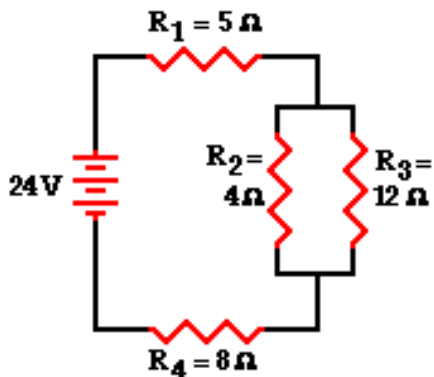

Voltage Drop in the Branches

- Circuit 24-volt source.
- Thus, the cumulative voltage drop of a charge traversing a loop about the circuit is 24 volts.
- There will be a 19.5 V drop (7.5 V + 12 V) resulting from passage through the two series-connected resistors (R_1 and R_4).
- The voltage drop across the branches must be 4.5 volts to make up the difference between the 24 volt total and the 19.5-volt drop across R_1 and R_4 . Thus, $\Delta V_2 = \Delta V_3 = 4.5 \text{ V}$

Nearly there.....

- Knowing the voltage drop across the parallel-connected resistors (R_2 and R_3) allows one to use the Ohm's law equation ($V = I \cdot R$) to determine the current in the 2 branches.

$$I_2 = \Delta V_2 / R_2 = (4.5 \text{ V}) / (4 \Omega)$$

$$I_2 = 1.125 \text{ A}$$

$$I_3 = \Delta V_3 / R_3 = (4.5 \text{ V}) / (12 \Omega)$$

$$I_3 = 0.375 \text{ A}$$

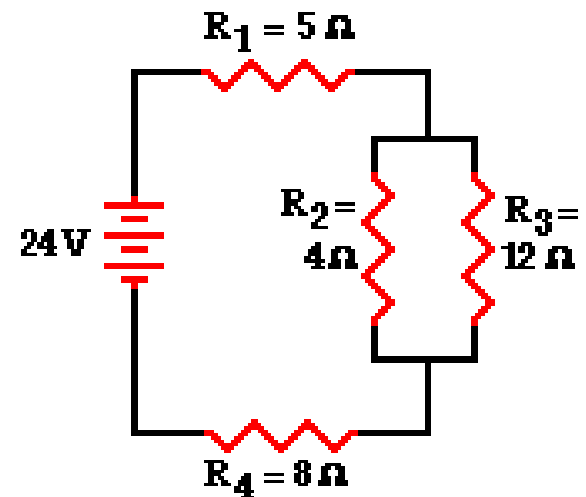

A Strategy

- If a schematic diagram is not provided, take the time to construct one.
- When approaching a problem involving a combination circuit, take the time to organize yourself, writing down known values and equating them with a symbol such as I_{tot} , I_1 , R_3 , V_2 , etc.
- Know and use the appropriate formulae for the equivalent resistance of series-connected and parallel-connected resistors.
- Transform a combination circuit into a strictly series circuit by replacing the parallel section with a single resistor having a resistance value equal to the equivalent resistance of the parallel section.
- Use the Ohm's law equation ($V = I \cdot R$) often and appropriately.
- Most answers will be determined using this equation.
- When using it, it is important to substitute the appropriate values into the equation. Calculating I_2 substitute the V_2 and the R_2 values into the equation.

The Complete Analysis

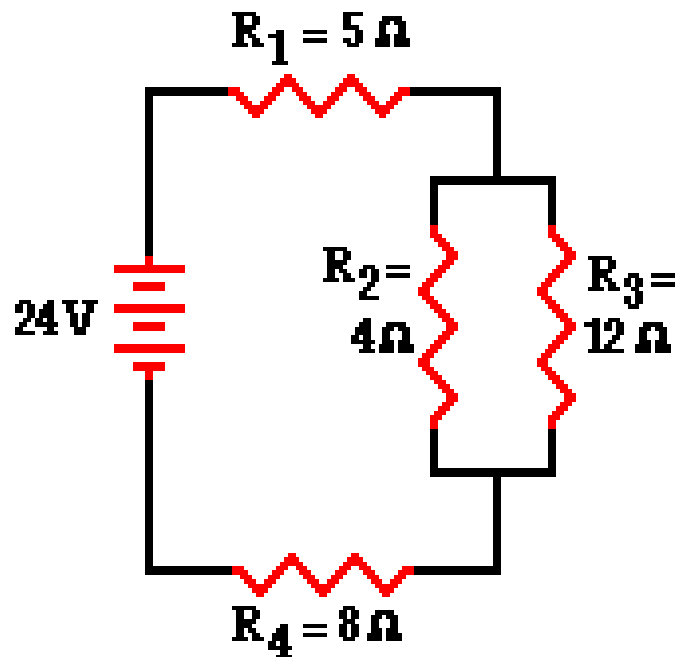

$$R_{\text{tot}} = \underline{16\ \Omega}$$

$$I_{\text{tot}} = \underline{15\ \text{A}}$$

$$I_1 = \underline{15\ \text{A}}$$

$$\Delta V_1 = \underline{75\ \text{V}}$$

$$I_2 = \underline{1.125\ \text{A}}$$

$$\Delta V_2 = \underline{45\ \text{V}}$$

$$I_3 = \underline{0.375\ \text{A}}$$

$$\Delta V_3 = \underline{45\ \text{V}}$$

$$I_4 = \underline{15\ \text{A}}$$

$$\Delta V_4 = \underline{12\ \text{V}}$$