

PQ7 Questions

Series Circuits

Q1

Identify which of these circuits is a *series* circuit (there may be more than one shown!):

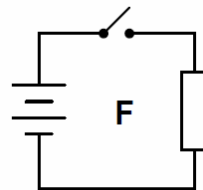
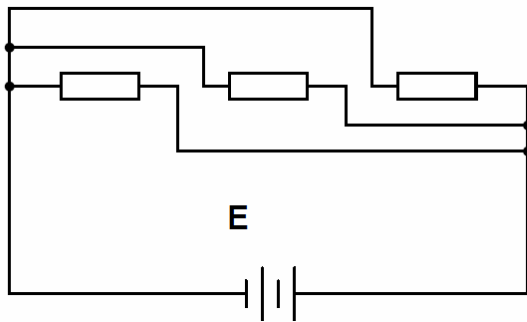
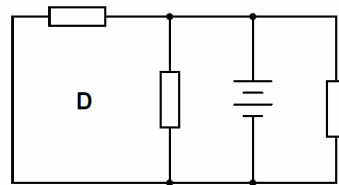
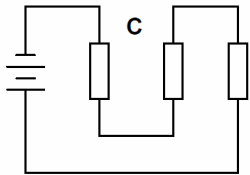
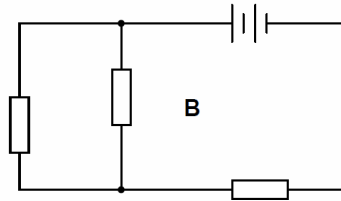
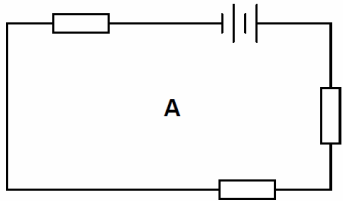

Q2

Most flashlights use multiple 1.5 volt batteries to power a light bulb with a voltage rating of several volts. Draw a schematic diagram of showing how multiple batteries may be connected to achieve a total voltage greater than any one of the batteries' individual voltages.

Q3

A technician wants to energize a 24 volt motor, but lacks a 24 volt battery to do it with. Instead, she has access to several "power supply" units which convert 120 volt AC power from a power receptacle into low-voltage DC power that is adjustable over a range of 0 to 15 volts. Each of these power supplies is a box with a power cord, voltage adjustment knob, and two output terminals for connection with the DC voltage it produces:

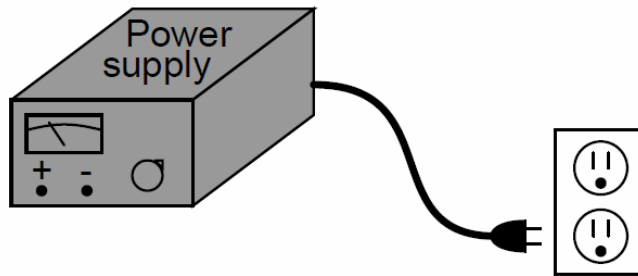

24 VDC
motor

Q4

How much voltage does the light bulb receive in this circuit? Explain your answer.

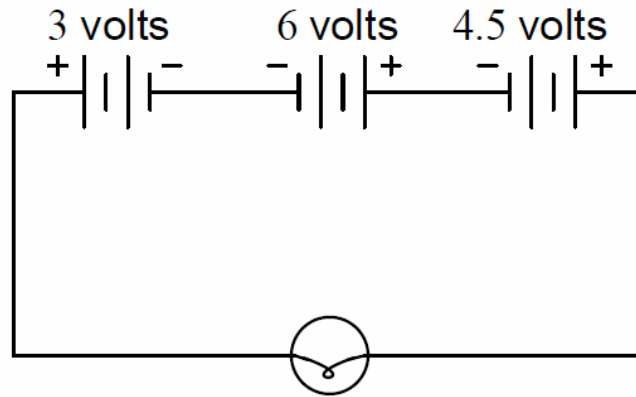

Also, identify the polarity of the voltage across the light bulb (mark with "+" and "-" signs).

Q5

How much voltage does the light bulb receive in this circuit? Explain your answer.

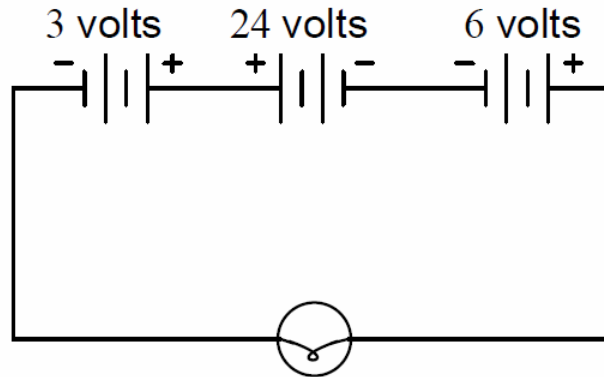

Also, identify the polarity of the voltage across the light bulb (mark with "+" and "-" signs).

Q6

Re-draw this circuit in the form of a schematic diagram:

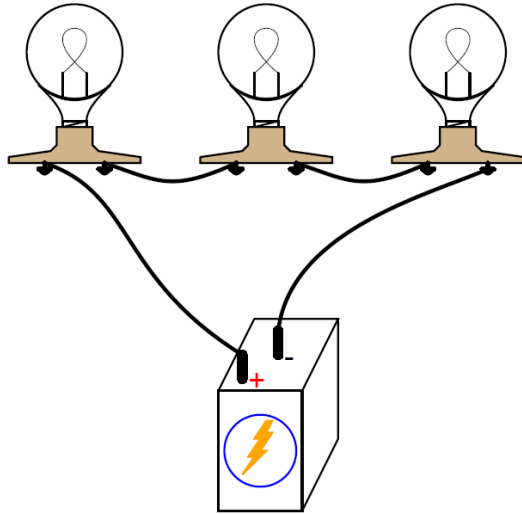

Q7

How much electrical resistance would you expect an ohmmeter to indicate if it were connected across the combination of these two series-connected resistors?

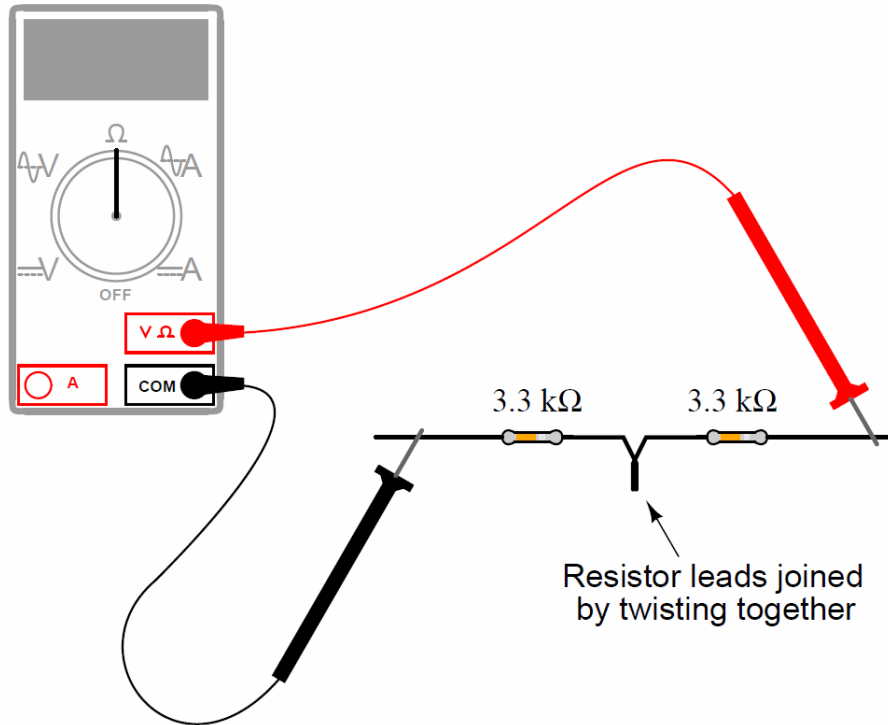

Q8

What would happen if three 6-volt light bulbs were connected as shown to a 6-volt battery? How would their brightnesses compare to just having a single 6-volt light bulb connected to a 6-volt battery?

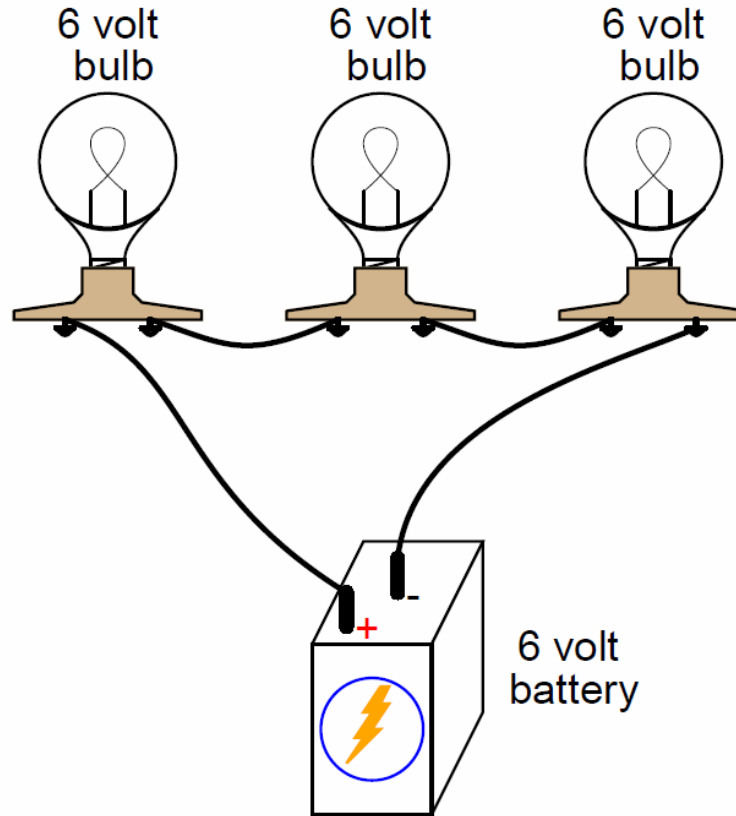

Q9

In this circuit, three resistors receive the same amount of current (4 amps) from a single source. Calculate the amount of voltage "dropped" by each resistor, as well as the amount of power dissipated by each resistor:

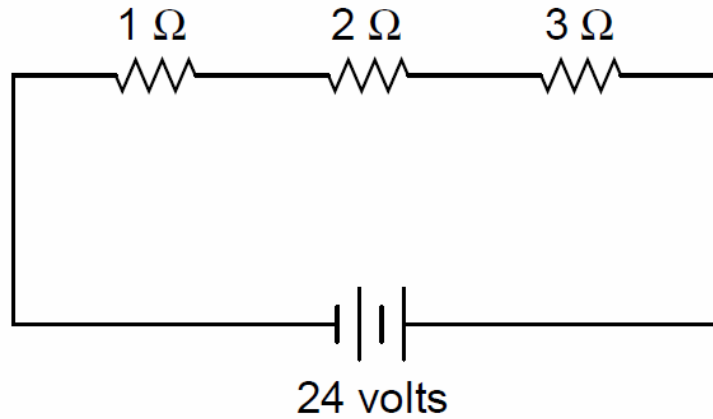

Q11

Explain, step by step, how to calculate the amount of current (I) that will go through each resistor in this series circuit, and also the voltage (V) dropped by each resistor:

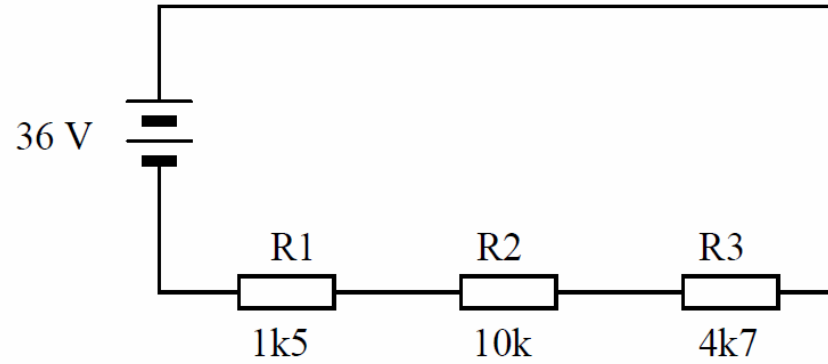

Q12

The brightness of a light bulb – or the power dissipated by any electrical load, for that matter – may be varied by inserting a variable resistance in the circuit, like this:

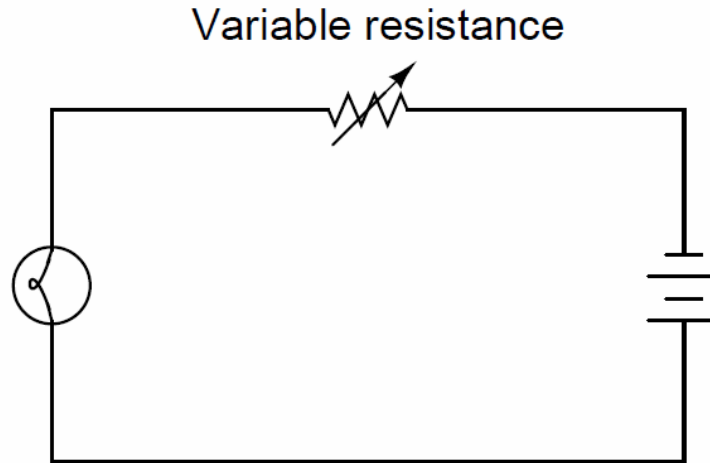

This method of electrical power control is not without its disadvantages, though. Consider an example where the circuit current is 5 amps, the variable resistance is $2\ \Omega$, and the lamp drops 20 volts of voltage across its terminals. Calculate the power dissipated by the lamp, the power dissipated by the variable resistance, and the total power provided by the voltage source. Then, explain why this method of power control is not ideal.

Q13

The circuit shown here is commonly referred to as a *voltage divider*. Calculate the voltage dropped across the following pairs of terminals, the current through each resistor, and the total amount of electrical resistance "seen" by the 9-volt battery:

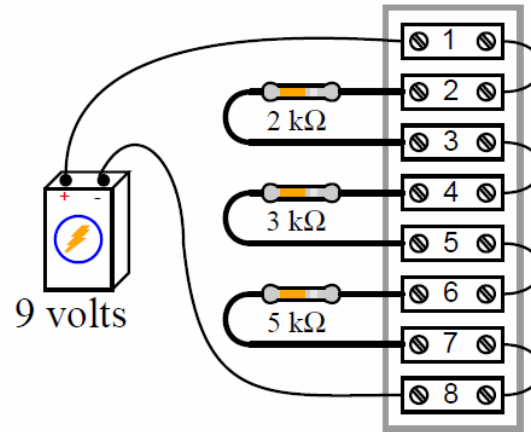

Voltage between terminals 2 and 3 =

Voltage between terminals 4 and 5 =

Voltage between terminals 6 and 7 =

Voltage between terminals 6 and 8 =

Voltage between terminals 4 and 8 =

Voltage between terminals 2 and 8 =

Current through each resistor =

R_{total} =

Q14

Complete the table of values for this circuit:

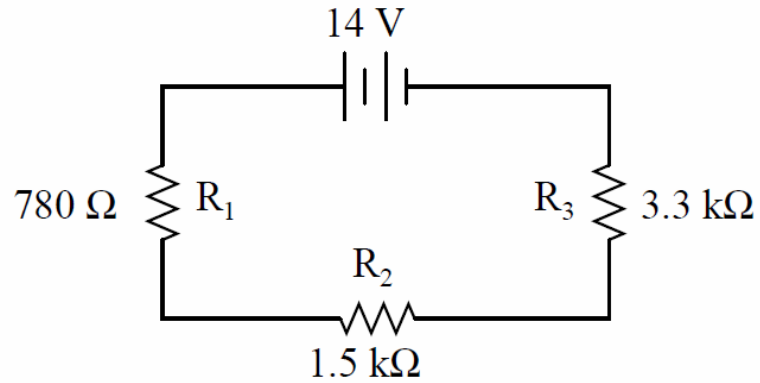

	R_1	R_2	R_3	Total
V				
I				
R	780 Ω	1.5 k Ω	3.3 k Ω	
P				

Q15

Complete the table of values for this circuit:

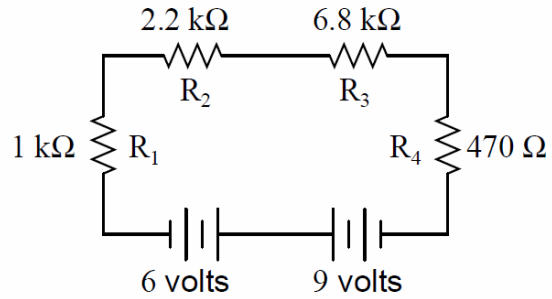

	R_1	R_2	R_3	R_4	Total
V					
I					
R	$1\text{ k}\Omega$	$2.2\text{ k}\Omega$	$6.8\text{ k}\Omega$	$470\ \Omega$	
P					

Q16

In a series circuit, certain general rules may be stated with regard to quantities of voltage, current, resistance, and power. Express these rules, using your own words:

”In a series circuit, voltage . . .”

”In a series circuit, current . . .”

”In a series circuit, resistance . . .”

”In a series circuit, power . . .”