

S2 Exam Practise Questions 8

Q

Q1

In a rowing event a boat moves off in a straight line.



A graph for the boat's motion is shown.

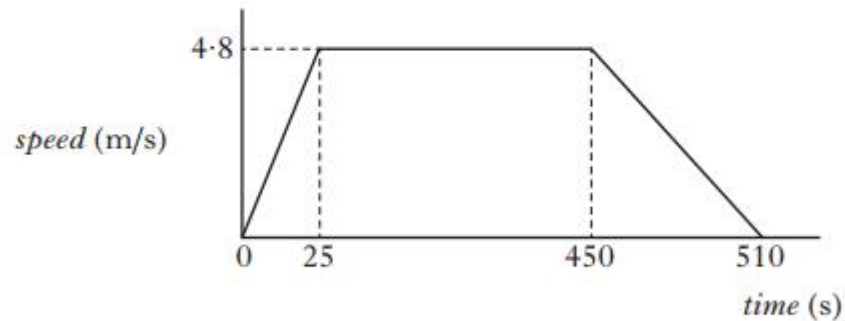

- (a) (i) Calculate the acceleration of the boat during the first 25 s. 2
- (ii) Describe the motion of the boat between 25 s and 450 s. 1
- (iii) Draw a diagram showing the horizontal forces acting on the boat between 25 s and 450 s. 2
- You **must** name these forces and show their directions.

Q1 continued

(b) The boat comes to rest after 510 s.

(i) Calculate the total distance travelled by the boat.

2

(ii) Calculate the average speed of the boat.

2

(9)

Q2



not to scale

The average forward force on the arrow is 500 N. The average frictional force acting on the arrow is 15 N. The arrow has a mass of 0.20 kg.

(a) Calculate the average acceleration of the arrow. 3

(b) The arrow hits the target and accelerates at -3600 m/s^2 . It comes to rest in 12 ms.

Calculate the velocity of the arrow just before it hits the target. 2

(c) A second arrow of mass of 0.10 kg is now fired at the target with the same average forward force and the same average frictional force.

Is the time taken for the second arrow longer, shorter or the same as the time taken for the first arrow to reach the target?

You **must** explain your answer. 2

(7)

Q3

The rocket engine in a spacecraft burns fuel producing exhaust gases.

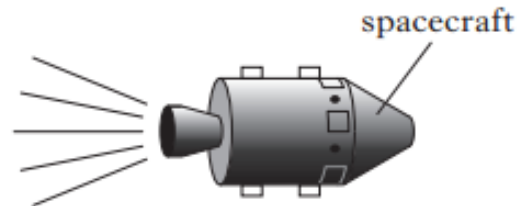

- (a) Identify the Newton pair of forces involved.
- (b) In deep space, the spacecraft approaches and docks with a stationary space station.

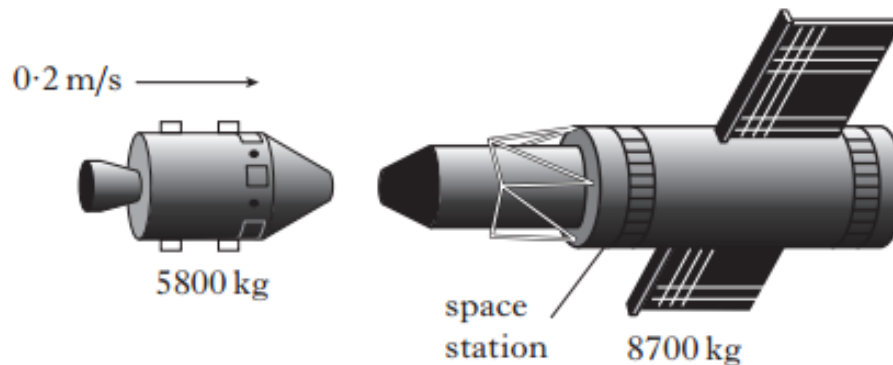

The spacecraft has a mass of 5800 kg and an initial velocity of 0.2 m/s . The space station has a mass of 8700 kg.

- (i) Calculate the velocity of the spacecraft and space station after they have docked.
- (ii) Calculate the kinetic energy of the spacecraft and space station after they dock.

Q4

The circuit shown is used to investigate the relationship between voltage and current for a filament lamp.

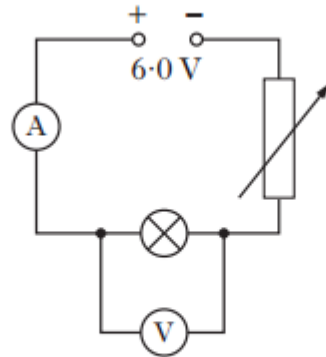

- (a) State the energy transformation in the filament lamp.
- (b) The variable resistor is altered and readings of current and voltage are taken. These values are plotted on the graph shown.

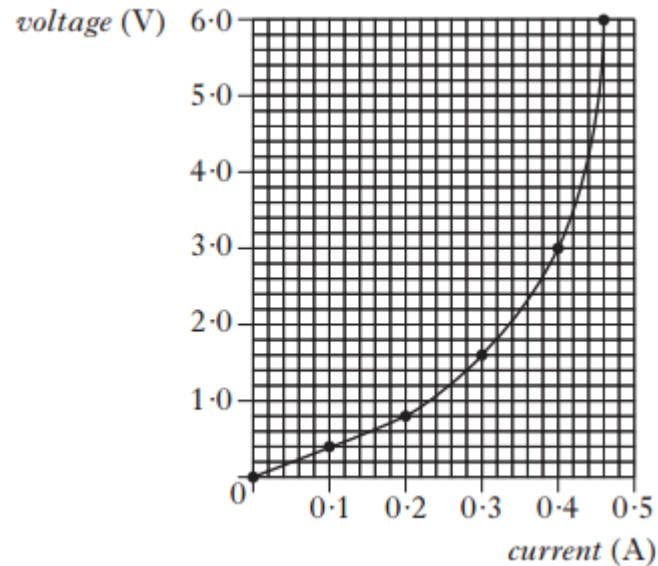

Q4 continued

- (i) Calculate the resistance of the filament lamp when the current is 0.4 A. 2
- (ii) What happens to the resistance of the filament lamp as the voltage across it increases?
You **must** justify your answer. 2

Q5

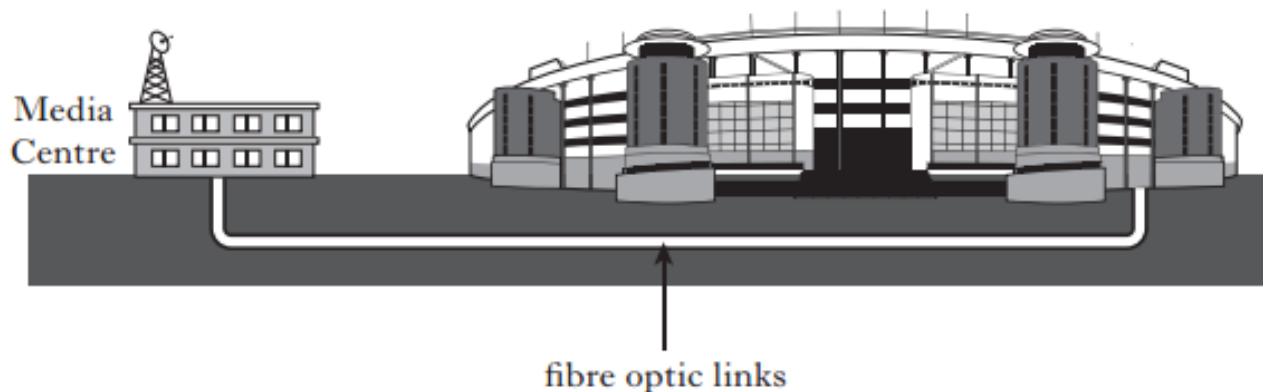

- (a) The fibre optic link consists of a bundle of glass optical fibres.
- (i) Name the effect used to transmit light through a glass optical fibre. **1**
 - (ii) The optical fibre has a length of 1.6 km. Calculate the minimum time taken for a light signal to travel along the fibre. **3**
- (b) Volunteers directing spectators use mobile phones for communication.
- (i) A mobile phone uses microwaves of frequency 1200 MHz. Calculate the wavelength of these microwaves. **2**
 - (ii) A second mobile phone operates with a frequency of 1800 MHz. The signals from each phone travel the same distance.
How does the time taken for the signals from the second phone compare with the signals from the first phone? **1**
- (7)**

Q6

An airport worker passes suitcases through an X-ray machine.



- (a) The worker has a mass of 80 kg and on a particular day absorbs 7.2 mJ of energy from the X-ray machine.
- (i) Calculate the absorbed dose received by the worker. 2
 - (ii) The radiation weighting factor for X-ray is 1.
Calculate the equivalent dose received by the worker. 2
- (b) The worker wears a badge containing photographic film.
Explain how this can indicate if the worker has been exposed to radiation. 1
- (c) X-rays can cause ionisation.
Explain what is meant by *ionisation*. 1
- (6)**

Q7

A nuclear reactor in a submarine uses uranium fuel rods. During a chain reaction uranium nuclei undergo nuclear fissions in the reactor.

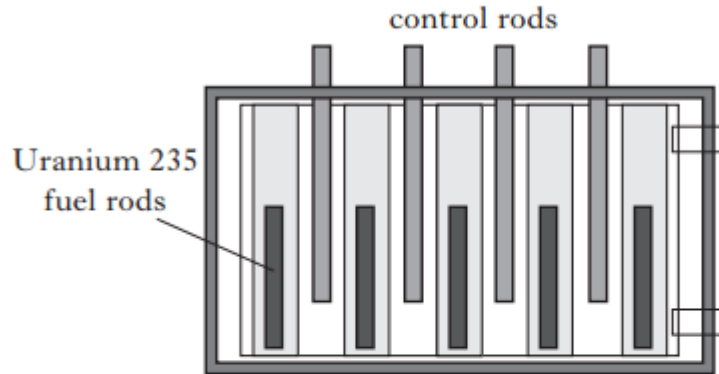

- (a) The reactor is fitted with boron control rods.

These can be lowered into the reactor.

What effect does this have on the chain reaction?

You **must** explain your answer.

2

- (b) The reactor produces 2.4×10^9 J of energy every minute.

Calculate the power produced by the reactor.

2

Q7 continued

- (c) A generator uses energy from the reactor to produce electrical energy. The generator is 36% efficient.

Calculate the power output of the generator.

2

- (d) Radioactive caesium is a waste product of the fission reaction.

Caesium has a half-life of 30 years.

- (i) A caesium sample was removed from the reactor on 1 January 1954. On 1 January 2014 the activity of the sample was 4×10^{12} Bq. Calculate the activity of the sample on 1 January 1954.

2

- (ii) Calculate how many nuclei would decay during a 5 minute period when the sample has an activity of 4×10^{12} Bq.

2

(10)

Q8

What is the wavelength that corresponds to a sound frequency of:

(a) 256 Hz;

(b) 25 kHz?

Take the speed of sound to be 330 m s^{-1} .

Q9

Jimi is practicing guitar in his room with the door open, as shown in the diagram at right. With reference to relevant physics principles, explain why Joni, in the hallway outside his room, can hear the sound of the guitar but not see Jimi. ¶

Q10

The clarinet is a wind instrument that behaves like a closed pipe with a fundamental frequency of 130 Hz in air at a room temperature of 25°C

What are the frequencies of the next two higher harmonics?

Q10 continued

Sketch the particle displacement vs distance envelopes for the fundamental frequency and for the next harmonic frequency above the fundamental for this instrument. → → (2 marks)¶

Q10 continued

Calculate the length of the clarinet

Q11

The clarinet is played so as to produce its fundamental frequency, and the sound is captured by a microphone and feed into an amplifier. Two loudspeakers X and Y are connected in phase to the amplifier and set up facing each other a distance of 8.5 m apart. A person walking from one of the loudspeakers towards the other hears points where the sound is extremely soft, alternating with points where it is loud.

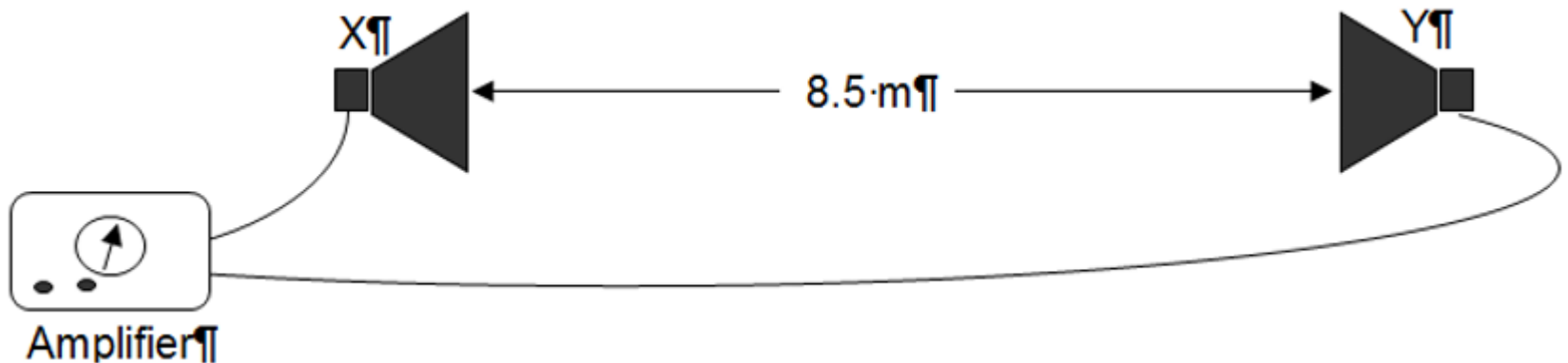

Q11 continued

Why will the person hear a series of soft and loud points as they walk from one loudspeaker towards the other? → → → → → → → → → (2 marks)¶

Q11 continued

Calculate whether the sound is loud or soft when the person walking between the loudspeakers is 2.92 m from speaker X.

What is the distance between a soft and a loud point?

Q12

A violin string is 0.65 m in length. Sketch the standing waves produced and determine the wavelengths of the 1st and 2nd harmonics.

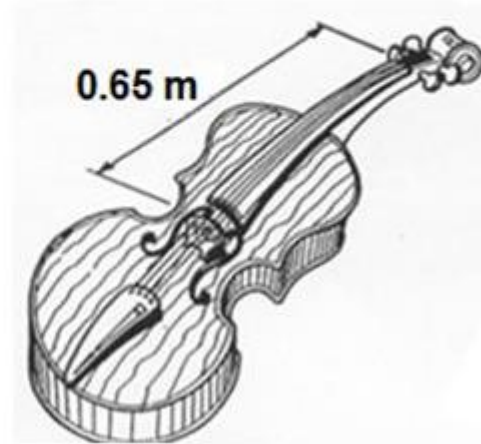

Q12 continued

If the wave speed on the string is 400 m s^{-1} , calculate the frequencies of the first two harmonics? → (3 marks)

Q13

A student heated 337 g of nickel in a Bunsen burner until it reached a temperature of 534°C . She then placed the nickel into 1.59 L of water at a temperature of 21.0°C . The final temperature of the nickel and water mixture was 32.3°C when they reached thermal equilibrium. ¶

Calculate the energy that transferred out of the nickel into the water.

Calculate the specific heat of the nickel.

Q14

- A longitudinal wave has a wavelength of 3.00 m and a speed of 1484 m s⁻¹. What is the frequency, f , of the wave?

Q15

- In ultrasound imaging, the speed of sound is 1540 m s^{-1} . The resolution of an image depends on the wavelength of the sound—a smaller wavelength (higher frequency) enables more detail to be seen with less effect of diffraction. High-frequency sound (5 to 10 MHz) can resolve more detail but has limited penetration depth, whereas low-frequency sound (2 to 5 MHz) can penetrate to deeper structures but has lower resolution.

The human heart is 10 cm across. 300 wavelengths need to fit into 10 cm.

Q15 continued

- If the frequency were significantly lower than your calculated amount, what would happen to the image? Explain why.

Q17

- Sam heard an annoying sound from 100 m away. By what factor would the intensity of the annoying sound change if Sam was to move to a distance of 400 m from the sound?

Q18

- A fog horn was originally heard from a boat when the boat was 1 km from the fog horn. After some time, the intensity of the fog horn was measured as being half of the original. Assuming the volume of the fog horn hadn't changed, how far away was the boat from the fog horn when the intensity was measured?