

S2 Examination Practise 4

Q and A

Q1

Question 1

(2 marks)

Explain why a 'space blanket' to protect against hypothermia has a shiny silver surface.

Question 1

(2 marks)

The shiny silver surface enables the space blanket to reflect heat back into the person's body to keep them warm.

Q2

Question 2

(2 marks)

When the Space Shuttle was flying space missions it had black ceramic tiles on its nose. What was the role of these tiles when the Shuttle re-entered the Earth's atmosphere?

Question 2

(2 marks)

As the Space Shuttle re-entered the Earth's atmosphere, air friction increased and produced huge amounts of heat. The tiles were designed to re-radiate the heat back into the atmosphere and away from the pilots and crew, thus protecting them from heating up too much.

Q3

Question 3

(2 marks)

Double-glazed windows offer more effective insulation than single-glazed windows. Explain how double-glazed windows achieve this.

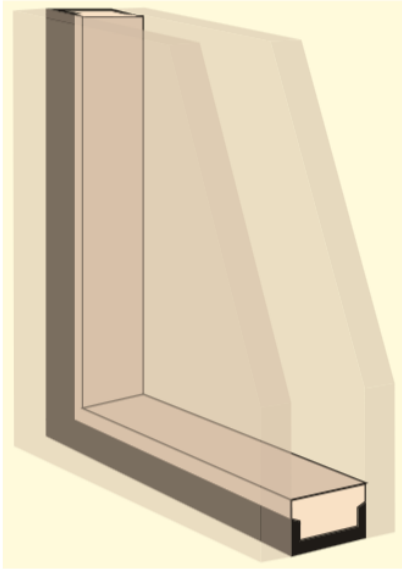

Double-glazed windows have two sheets of glass with a small air gap between them. The air trapped in the gap is an insulator, reducing heat conduction through the window. The fact that the air is trapped and cannot circulate reduces the effect of convection. (Note: Double glazing has minimal effect on radiation.)

Q4

Question 4

(4 marks)

A vacuum flask (as shown below) can be used to keep hot liquids hot. In the diagram, five design features of a flask are labelled. Explain how each of the features cuts down heat loss.

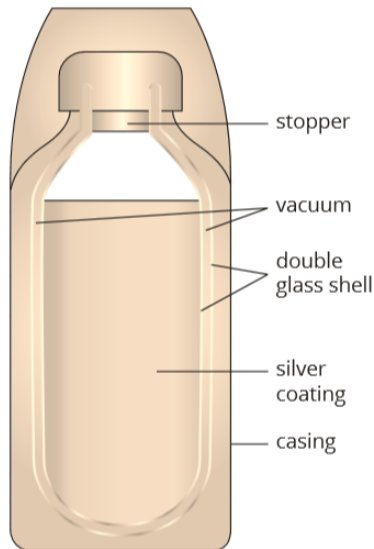

The vacuum in the double glass shell is an insulator and reduces heat loss by conduction and, being a vacuum, reduces convection in the shell. The silver coating reflects heat back into the liquid, reducing heat loss.

The stopper reduces evaporation from the surface and convection in the air space above the liquid. The double glass shell is an insulator and reduces heat loss by conduction.

Q5

Question 5

(2 marks)

${}_{28}^{58}\text{Ni}$ and ${}_{28}^{63}\text{Ni}$ are both isotopes of nickel. Explain the meaning of the term 'isotope', referring to these two atoms as examples.

Isotopes are atoms that have the same number of protons but different numbers of neutrons in their nuclei. Both ${}_{28}^{58}\text{Ni}$ and ${}_{28}^{63}\text{Ni}$ have 28 protons in their nuclei. However, ${}_{28}^{63}\text{Ni}$ has 35 neutrons in its nucleus and ${}_{28}^{58}\text{Ni}$ only has 30. So they are both isotopes of nickel.

Q6

Question 6

(2 marks)

${}_{28}^{63}\text{Ni}$ is a radioisotope of nickel. Explain what the term 'radioisotope' means. Explain why ${}_{28}^{63}\text{Ni}$ is radioactive and ${}_{28}^{58}\text{Ni}$ is not radioactive.

Radioisotopes are isotopes of an atom that are also radioactive. ${}_{28}^{63}\text{Ni}$ is radioactive because the extra 5 neutrons it has in its nucleus compared to ${}_{28}^{58}\text{Ni}$ makes its nucleus unstable. (To become more stable the ${}_{28}^{63}\text{Ni}$ atom will undergo radioactive decay to 'lose' its excess energy.)

Q7

Question 7

(1 mark)

Explain what is meant by the nuclear binding energy of an atom.

Nuclear binding energy is the energy needed to totally separate the nucleus of an atom into its component protons and neutrons.

Q8

Question 8

(1 mark)

A controlled chain reaction is required to sustain nuclear fission inside a nuclear reactor. For this to occur, what number of neutrons per fission needs to be released?

The number of neutrons released per fission needs to be greater than one.

Q9

Question 9

(2 marks)

Cadmium is often used to control the rate of nuclear fission in a reactor. How does cadmium achieve this?

Cadmium absorbs neutrons (without undergoing fission itself) thus preventing them from causing further nuclear fission.

Q10

Question 10

(2 marks)

In the nuclear reaction ${}_{92}^{235}\text{U} + {}_0^1\text{n} \rightarrow {}_{92}^{236}\text{U} \rightarrow {}_{56}^{141}\text{Ba} + {}_{36}^{92}\text{Kr} + X + \text{energy}$, what would X be?

X is 3 neutrons (${}_0^1\text{n}$)

In a nuclear equation the total number of nucleons and the number of protons on each side of the equation must be equal. The right-hand side of the equation requires three more neutrons to achieve balance.

Q11

Question 11

(3 marks)



If the mass defect as a result of this nuclear reaction is 2.12×10^{-28} kg, how much energy would be released in MeV?

$$\begin{aligned} E &= \Delta mc^2 \\ &= 2.12 \times 10^{-28} \times (3.0 \times 10^8)^2 \\ &= 1.91 \times 10^{-11} \text{ J} \\ &= \frac{1.91 \times 10^{-11}}{1.6 \times 10^{-19}} \text{ eV} \\ &= 120 \times 10^8 \text{ eV} = 120 \text{ MeV} \end{aligned}$$

Q12

Question 12

(3 marks)

A student constructs two circuits, as shown below. She wants each circuit to have the same effective resistance. The resistors are all identical.

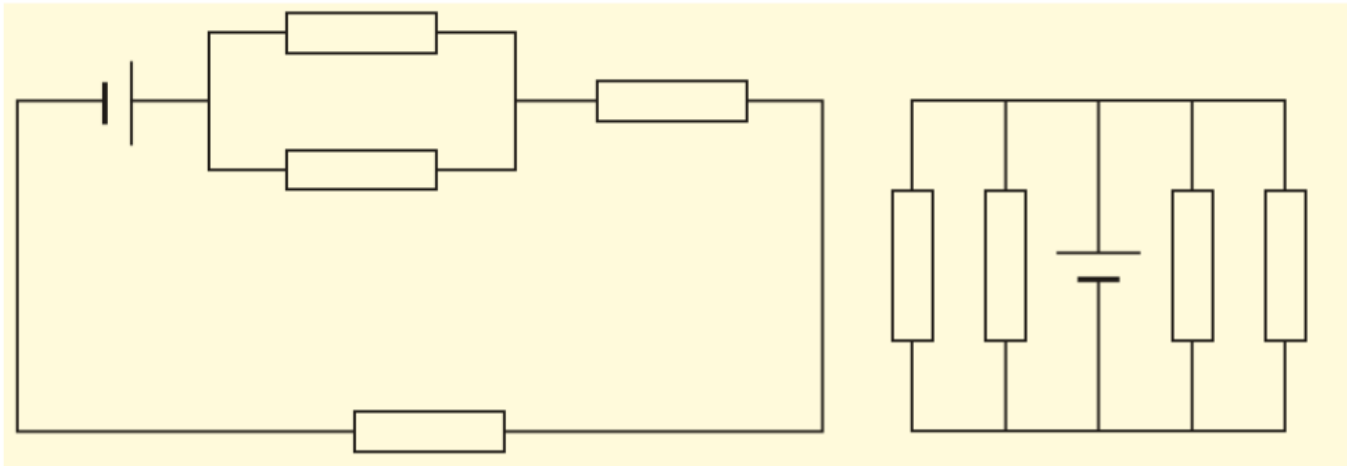

Has she achieved her aim? Use calculations to prove your answer.

$$\text{Effective resistance of circuit 1} = \frac{1}{2}R + R + R = 2.5R$$

$$\text{Effective resistance of circuit 2} = \frac{1}{R_{\text{TOTAL}}} = \frac{1}{R} + \frac{1}{R} + \frac{1}{R} + \frac{1}{R} = \frac{4}{R}$$

$$R_{\text{TOTAL}} = \frac{R}{4}$$

Therefore the resistance of each circuit is different. The student did not achieve her aim.

(Students may substitute a value for R to work out the resistance of each circuit and compare them.)

Q13

(4 marks)

Distinguish between the internal electrical resistance of ammeters and voltmeters, and give reasons for those differences.

Ammeters are designed to have negligible resistance, whereas voltmeters are designed to have the maximum possible resistance.

Ammeters need to have negligible resistance so that they do not alter the original value of the current in the circuit to be tested.

Voltmeters need to have high resistance so that they do not divert significant current away from the original circuit.

Q14

Consider the following displacement versus time graph. Sketch the shapes of its matching velocity versus time graph and acceleration versus time graph.

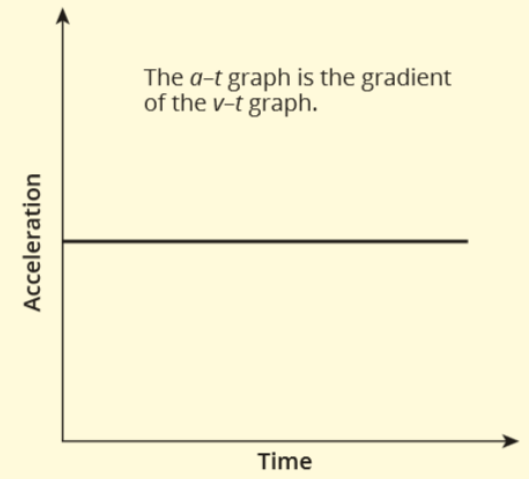
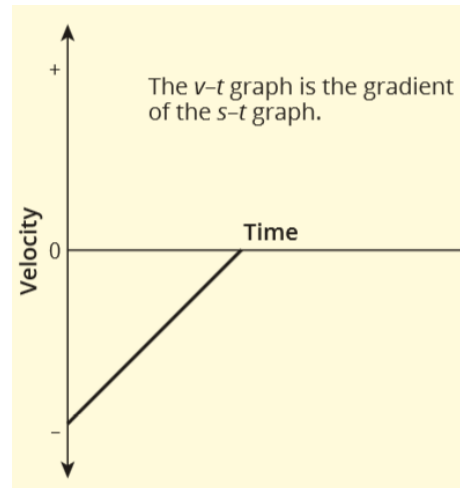
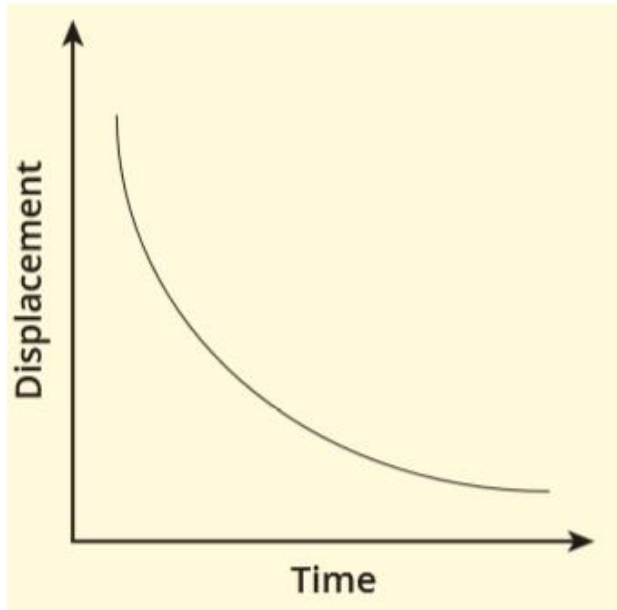

Q15

(4 marks)

Two vehicles are approaching each other at a T-intersection. Neither vehicle stops, and the vehicles subsequently collide.

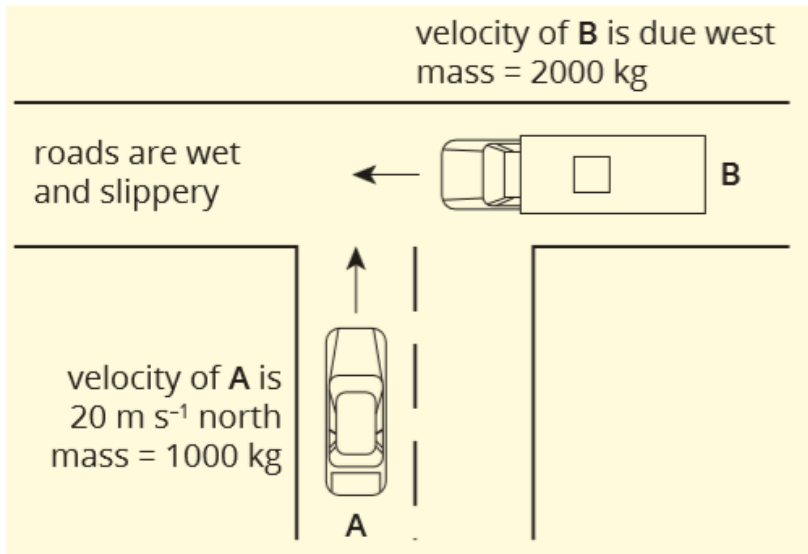

After the impact the car becomes jammed under the truck and the two vehicles skid off as one mass with a velocity of 9.43 m s^{-1} north 45° west.

The driver of the truck claims that he was travelling at 5 m s^{-1} , just before the collision. Is he correct? If not, explain why.

Q15 continued

The law of conservation of momentum will apply in this situation—it can be considered to be an isolated or closed system since external forces such as friction between the road and vehicles are negligible. The total momentum of the system before impact must equal the total momentum of the vehicles after impact.

$$p_{\text{final}} = (m_1 + m_2) v = (1000 + 2000) \times 9.43 = 2.83 \times 10^4 \text{ kg m s}^{-1} \text{ at N } 45^\circ \text{ W}$$

Since this is at 45° , the vector triangle of initial and final momenta form an isosceles right-angled triangle, and therefore the momentum of both vehicles before the collision was the same magnitude.

$$p_{\text{truck before}} = p_{\text{car before}} = \sqrt{\frac{(2.83 \times 10^4)^2}{2}} = 2.0 \times 10^4 \text{ kg m s}^{-1}$$

$$2.0 \times 10^4 = 2000 \times u_{\text{truck}}$$

$$\therefore u_{\text{truck}} = \frac{2.0 \times 10^4}{2000} = 10 \text{ m s}^{-1}$$

The driver of the truck is incorrect. The speed of the truck must have been greater than the 5 m s^{-1} the driver stated.

Q16

(3 marks)

A 1000 kg vehicle is accelerated from rest to a speed of 17.8 m s^{-1} over 9.4 s. Determine the size of the net force acting on the vehicle during this time.

$$u = 0, v = 17.8 \text{ m s}^{-1}, t = 9.4 \text{ s}, a = ?$$

$$v = u + at$$

$$17.8 = 0 + 9.4a \rightarrow a = \frac{17.8}{9.4} = 1.89 \text{ m s}^{-2}$$

$$F_{\text{net}} = m \times a = 1000 \times 1.89 = 1890 \text{ N or } 1.89 \times 10^3 \text{ N}$$

Q17

(3 marks)

A 1600 kg vehicle travelling at 14.5 m s^{-1} slows to a halt over a distance of 350 m. Determine the combined total of the frictional force and the air resistance that slows the vehicle down.

$$u = 14.5 \text{ m s}^{-1}, v = 0 \text{ m s}^{-1}, s = 350 \text{ m}, a = ?$$

$$v^2 = u^2 + 2as$$

$$0 = 14.5^2 + 700a$$

$$a = \frac{14.5^2}{-700} = -0.3004 \text{ m s}^{-2}$$

$$F = ma = 1600 \times 0.3004 = 481 \text{ N}$$

Q18

(2 marks)

Why does light refract?

Because light effectively slows down when it enters a medium with a higher refractive index (or speeds up in a medium with a lower refractive index). This change in speed causes the wave to bend or refract if the ray enters at an angle greater than 0° to the normal.

Q19

(2 marks)

What type of interference will occur if two identical waves arrive at a point, 180° out of phase?
Explain your answer.

Destructive, as the crest of one wave will cancel out the trough of the other (or vice versa).

Q20

(3 marks)

A light bulb, when viewed from a distance of 5.0 m, has an intensity of 0.32 W m^{-2} . At what distance from the light bulb would the intensity be 0.50 W m^{-2} ?

$$I \propto a \propto \frac{1}{r^2} \text{ or } Ir^2 = \text{a constant, } k$$

$$k = 0.32 \times 5^2 \\ = 8.0$$

$$I_2 (r_2)^2 = 8.0$$

$$(r_2)^2 = \frac{8.0}{0.5} = 16$$

$$r_2 = 4.0 \text{ m}$$

Q21

James Bond, 007, likes to drink cocktails. On a warm afternoon (26°C), 007 is mixing cocktails whilst the ice is melting (0°C) in a bowl. Note: the specific heat capacity of the cocktails is $2.7 \times 10^3 \text{ J kg}^{-1} \text{ }^\circ\text{C}^{-1}$.

- a** A colleague of 007, 006, likes her cocktails served at 0°C. What is the minimum mass of ice cube she should select to cool her 60 g cocktail from 26°C to 0°C? (2 marks)

a energy lost by cocktails = energy gained by melting ice

$$mc\Delta T (\text{cocktails}) = mL_f (\text{ice})$$

$$0.06 \times 2.7 \times 10^3 \times 26 = m (\text{ice}) \times 3.34 \times 10^5$$

$$m (\text{ice}) = \frac{4.212 \times 10^3}{3.34 \times 10^5} = 0.0126 \text{ kg or } 12.6 \text{ g}$$

- b** 007 prefers his 60 g cocktail served at 10°C and shaken not stirred! What mass of ice cube will he need to cool his drink from 26°C to this temperature? (3 marks)

b energy lost by cocktails = energy gained by melting ice to water and heating water.

$$mc\Delta T (\text{cocktails}) = mL_f (\text{ice}) + mc\Delta T (\text{water})$$

$$0.06 \times 2.7 \times 10^3 \times 16 = m (\text{ice}) \times ((3.34 \times 10^5) + (4.18 \times 10^3 \times 16))$$

$$m (\text{ice}) = \frac{2.592 \times 10^3}{4.01 \times 10^5} = 0.00647 \text{ kg or } 6.47 \text{ g}$$

Q21 continued

- c** Another colleague, 008, decides he wants a cup of tea. He uses a 2000 W mains-operated kettle filled with 1.20 kg of water at room temperature (26°C). How long will he have to wait for the water to reach boiling point (100°C)? (2 marks)

$$\mathbf{c} \quad E = Pt = mc\Delta T$$

$$2000 \times t = 1.20 \times 4.18 \times 10^3 \times (100 - 26)$$

$$t = \frac{371\,184}{2000} = 186 \text{ s}$$

- d** In reality, it takes a little longer than this to boil the kettle. Give one good reason why it would take longer. (1 mark)
- d** Some of the heat energy goes into heating the kettle itself and some escapes into the air, so more heat energy is needed to heat the water, thus taking longer to boil.
- e** After several minutes it is noticed that there are drops of liquid water on the outside surfaces of the cold cocktail glasses. Explain why this effect occurs and describe what thermal effect this will have on the remaining contents of the glass.
- e** Explanation: Water vapour in the air next to the glass cools and liquefies producing the water droplets.
- Description: The water vapour in the air loses heat to the glass as it changes state from a vapour to a liquid (condenses) so the temperature of the glass and the cocktail in it will increase.

Q22

(5 marks)

The graph below shows the temperature–time relationship for the heating of 0.25 kg of soft wax by an electrical heater supplying 50 J of heat energy per second.

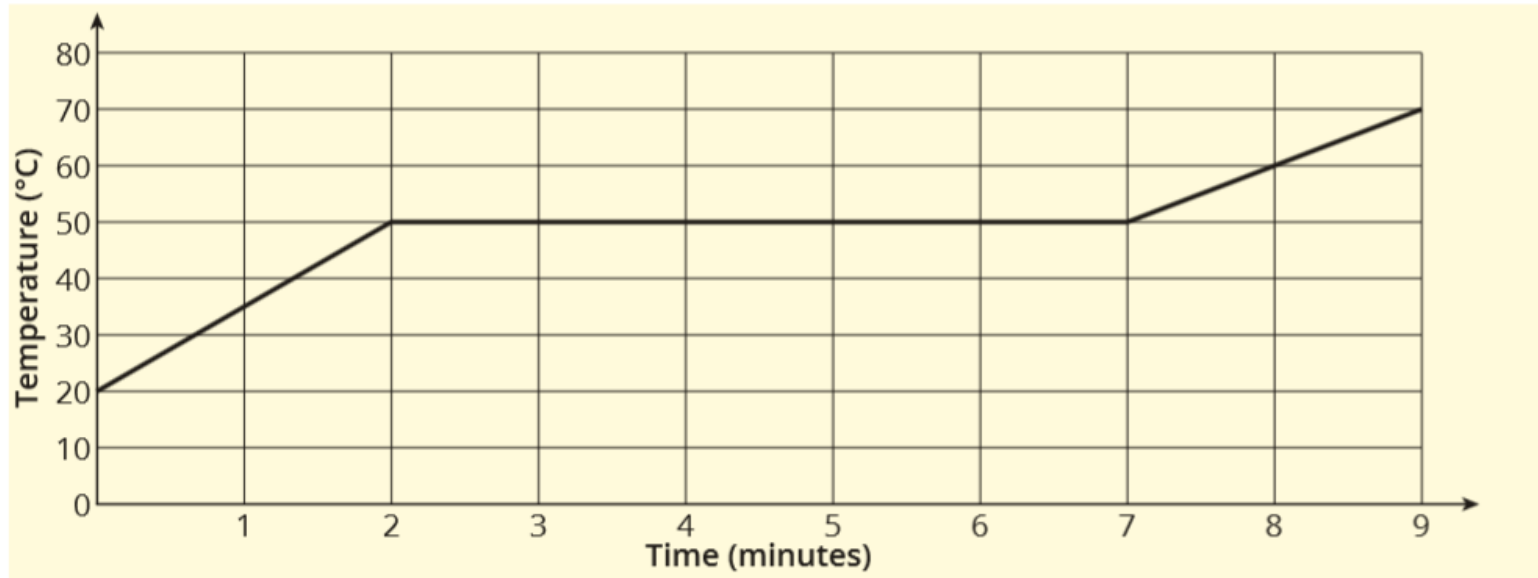

a Determine the wax's melting temperature. (1 mark)

b Find the latent heat of fusion (L_f) of the wax. (2 marks)

a 50°C (The melting temperature is shown by the plateau, i.e. flat section, on the graph.)

b $E = mL_f$

$$50 \times 5 \times 60 = 0.25 \times L_f$$

$$L_f = \frac{15\,000}{0.25} = 6.0 \times 10^4 \text{ J kg}^{-1}$$

Q23

(6 marks)

- a Complete the nuclear decay equation for Ni-63 when it emits a beta particle by placing the appropriate numbers and symbols in the boxes below: (4 marks)

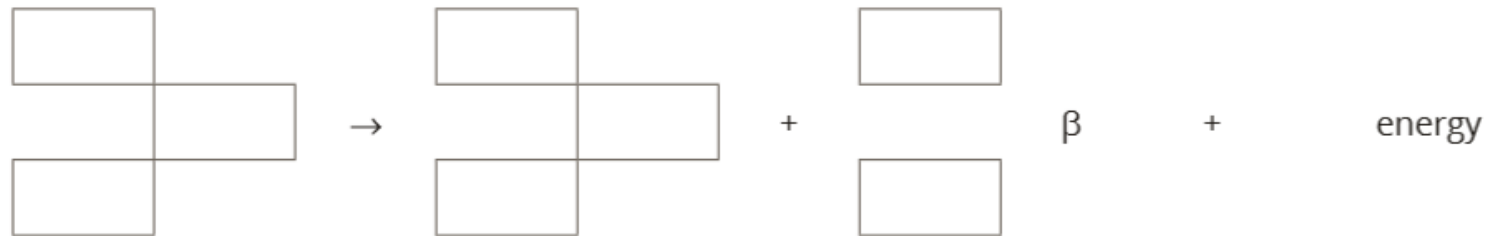

- b Explain where the emitted beta particle has come from and how it was produced. (2 marks)

(6 marks)

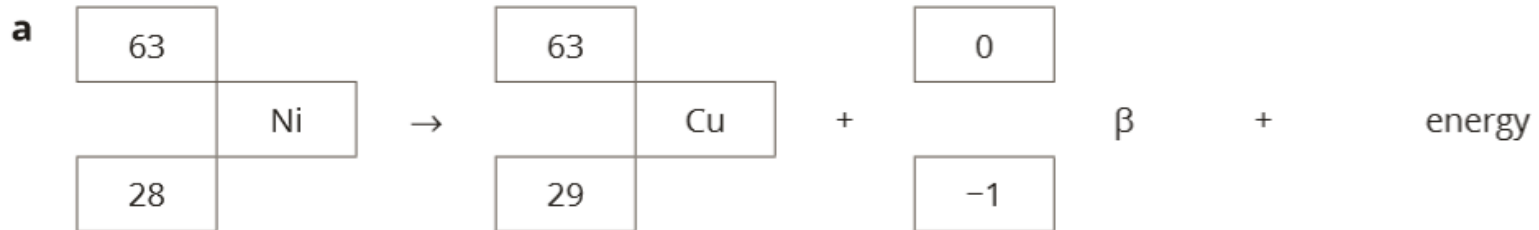

Q24

(8 marks)

Polonium-215 atoms decay into atoms of lead-211 by emitting an alpha particle.

The average kinetic energy of the emitted alpha particle is 7.39 MeV.

Polonium-215 has a half-life of 1.78×10^{-3} s.

$$1.00 \text{ eV} = 1.6 \times 10^{-19} \text{ J}$$

a What is the average kinetic energy of an emitted alpha particle in joules?

(2 marks)

$$\begin{aligned} \mathbf{a} \quad E &= 7.39 \times 10^6 \times 1.6 \times 10^{-19} \\ &= 1.18 \times 10^{-12} \text{ J} \end{aligned}$$

As an alpha particle travels through air it will ionise about 100 000 atoms for every centimetre travelled. Each time an alpha particle ionises an atom, the alpha particle will lose about 34 eV of its kinetic energy.

b Approximately how much energy would an alpha particle lose as it passes through 1.0 cm of air?

(2 marks)

$$\mathbf{b} \quad E = 100\,000 \times 34 \text{ eV} = 3.4 \times 10^6 \text{ eV or } 3.4 \text{ MeV}$$

Q24 continued

- c Calculate the approximate distance that an alpha particle with a kinetic energy of 7.39 MeV will travel in air before it loses all of its energy. Give your answer to the nearest millimetre.
(2 marks)

c distance = $\frac{7.39}{3.4} = 2.17$ cm or 21.7 mm

- d What percentage of the original sample of polonium-215 would be left after 4.13×10^{-3} s?
(2 marks)

$$N = N_0 \left(\frac{1}{2}\right)^n$$

$$n = \text{number of half-lives that have passed} = \frac{4.13 \times 10^{-3}}{1.78 \times 10^{-3}} = 2.32$$

$$N = 100 \times \left(\frac{1}{2}\right)^{2.32} = 20\%$$

Q25

(7 marks)

The diagram below illustrates the use of a type of taser that is sometimes used by police. A taser is a device designed to subdue a person by making them part of an electric circuit and then sending pulses of electrical current into their body.



When operating:

- the taser sends 10 pulses of electric current each second
- each pulse of current lasts for 1.00×10^{-4} s
- during each pulse 1.90×10^{-3} A of current flows
- during each pulse the potential difference across the circuit at the points of contact is 350 V.

a How much charge passes through the person's body during a single pulse from the taser? (2 marks)

$$\mathbf{a} \quad q = It = 1.9 \times 10^{-3} \times 1.00 \times 10^{-4} = 1.90 \times 10^{-7} \text{ C}$$

Q25 continued

- b** How many electrons would flow through the wires of the taser during a single pulse? (2 marks)

$$\begin{aligned}\mathbf{b} \quad \text{number of electrons} &= \frac{q}{1.6 \times 10^{-19}} \\ &= \frac{1.9 \times 10^{-7}}{1.6 \times 10^{-19}} = 1.19 \times 10^{12} \text{ electrons}\end{aligned}$$

- c** How much electrical energy is delivered in 2.00 s? (3 marks)

$$\mathbf{c} \quad E = VIt = 350 \times 1.9 \times 10^{-3} \times (1.00 \times 10^{-4} \times 10 \times 2.00) = 1.33 \times 10^{-3} \text{ J}$$

Q26

- Consider the following circuit, in which three resistors are connected to a variable power supply.

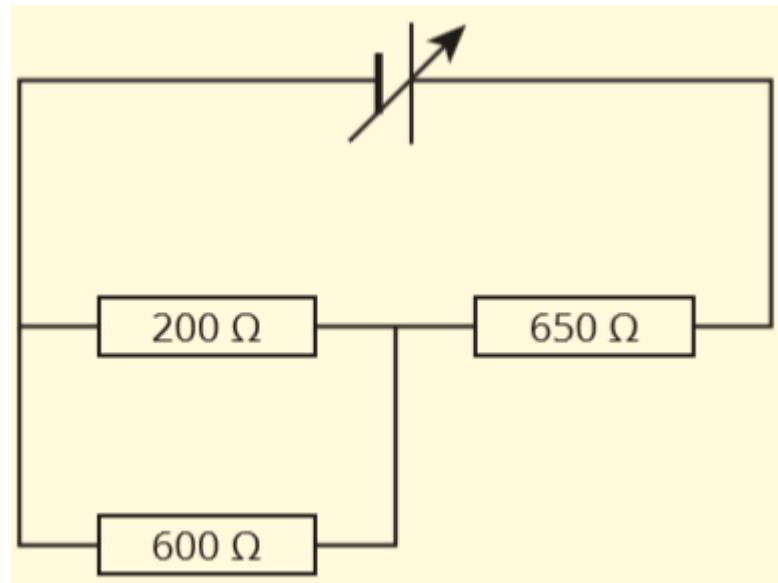

Q26 continued

a Show, by calculation, that the total resistance of the circuit is 800Ω . (3 marks)

a Calculate the effective resistance for the parallel part of the circuit first.

$$\frac{1}{R_{//}} = \frac{1}{200} + \frac{1}{600}$$

$$\frac{1}{R_{//}} = \frac{4}{600} = \frac{1}{150}$$

$$R_{\text{parallel}} = 150 \Omega$$

$$R_{\text{total}} = 150 + 650 = 800 \Omega$$

b Calculate the current that flows through the 600Ω resistor when the output of the power supply is 6.00 V . (4 marks)

b Firstly, calculate the total current flowing in the circuit:

$$I = \frac{V}{R} = \frac{6.0}{800} = 7.5 \times 10^{-3} \text{ A or } 7.5 \text{ mA}$$

$$V_{\text{parallel pair}} = IR = 7.5 \times 10^{-3} \times 150 = 1.125 \text{ V}$$

$$I_{600} = \frac{V}{R} = \frac{1.125}{600} = 1.88 \times 10^{-3} \text{ A or } 1.88 \text{ mA}$$

Q27

- Sam was driving his car at a constant speed of 54 km h^{-1} along a straight stretch of road. The total mass of the car and driver is 1600 kg .
- **a.** Use an appropriate calculation to show that Sam's car was moving at a constant speed of 15 m s^{-1} . (1 mark)

$$\mathbf{a} \quad v = \frac{54}{3.6} = 15 \text{ m s}^{-1}$$

- Sam saw a traffic light in front of him change from green to red. It took him 1.2 s to see the light change and make the decision to apply his brakes in order to stop the car.
- **b** From the moment the traffic light turned red, what distance did the car travel before Sam applied the brakes? (2 marks)

$$\mathbf{b} \quad u = 15, t = 1.2 \text{ s}, a = 0 \text{ m s}^{-2}, s = ?$$

$$s = ut + \frac{1}{2}at^2$$

$$= 15 \times 1.2 + 0 = 18 \text{ m}$$

Q27 continued

- **c** Once San applied the brakes it took the car 4.4 s to come to a stop. Assuming the deceleration was constant, what was the magnitude of the car's deceleration? (2 marks)

$$\mathbf{c} \quad u = 15 \text{ m s}^{-1}, v = 0 \text{ m s}^{-1}, t = 4.4 \text{ s}, a = ?$$

$$v = u + at$$

$$0 = 15 + 4.4a$$

$$a = \frac{-15}{4.4} = 3.41 \text{ m s}^{-2}$$

- **d** If Sam's car came to a stop next to the traffic light, how far from it had he been when she first saw it change from green to red? (3 marks)

d stopping distance (SD) = reaction distance (RD) + braking distance (BD)

RD = 18 m (from part b)

BD: $u = 15 \text{ m s}^{-1}, v = 0 \text{ m s}^{-1}, t = 4.4 \text{ s}, a = -3.41 \text{ m s}^{-2}, s = ?$

$$s = \frac{1}{2} (u + v)t$$

$$s = \frac{1}{2} (15 + 0) \times 4.4 = 33 \text{ m}$$

$$\therefore \text{stopping distance} = 18 + 33 = 51 \text{ m}$$

Q27 continued

- e How much work was done by the car's brakes in bringing the car to a stop? (3 marks)

e work done = change in energy = Δke

$$\Delta ke = \frac{1}{2} m(\Delta v)^2 = 0.5 \times 1600 \times 15^2 = 180\,000 \text{ J or } 1.8 \times 10^5 \text{ J}$$

or

work done = force \times distance

$$F = ma$$

$$F = 1600 \times 3.41 = 5455 \text{ N}$$

$$W = 5455 \times 33 = 180\,000 \text{ J or } 1.80 \times 10^5 \text{ J}$$

Q28

(13 marks)

The graph below shows part of a journey taken by a student on a bus. The bus and its passengers have a combined mass of 32 000 kg.

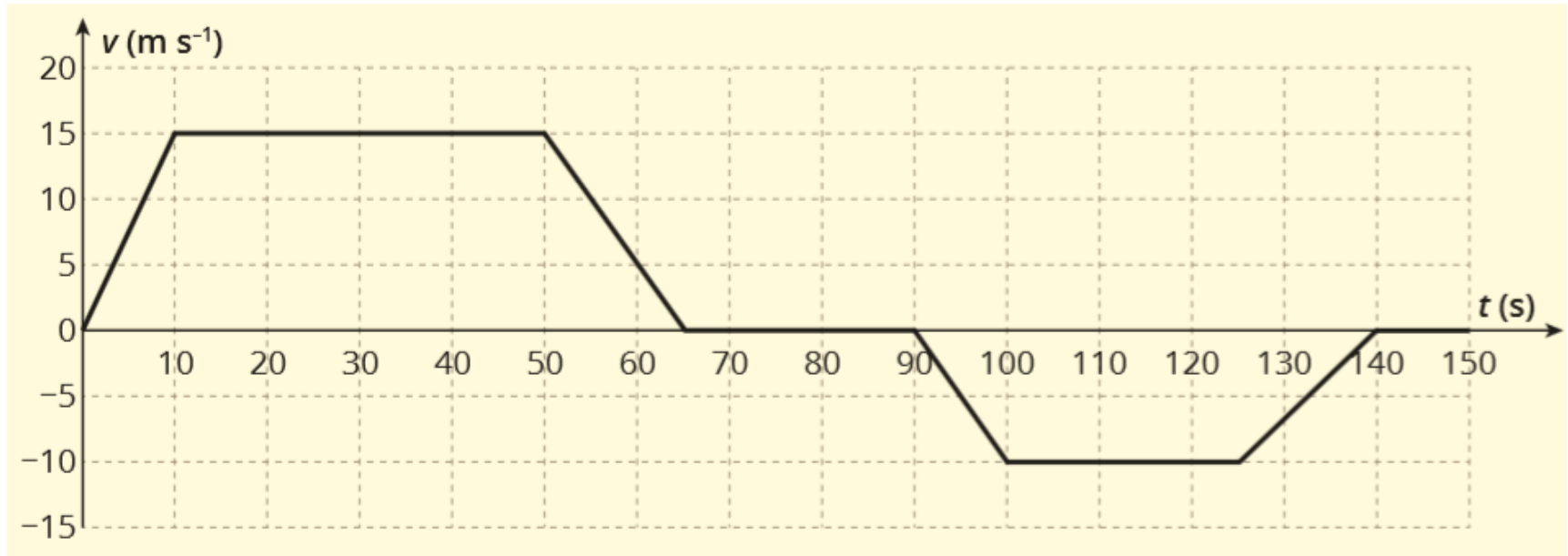

a What was the magnitude of the bus's acceleration at $t = 60$ s? (2 marks)

a acceleration = gradient of the v - t graph at $t = 60$ s

$$\text{gradient} = \frac{\text{rise}}{\text{run}} = \frac{0 - 15}{65 - 50} = -1.0 \text{ m s}^{-2}$$

$$\therefore \text{acceleration} = -1.0 \text{ m s}^{-2}$$

Q28 continued

b What was the net force acting on the bus at $t = 110$ s? Explain your answer. (2 marks)

b $F_{\text{net}} = 0$ (constant velocity means $a = 0$ and $F_{\text{net}} = ma$)

c If the driving force provided by the bus's engine during the first 10 s of the journey was a constant 61.3 kN, what average resistive force acted against the bus during this time? (4 marks)

c acceleration = gradient between $t = 0$ and $t = 10$ s

$$\text{gradient} = \frac{\text{rise}}{\text{run}} = \frac{0 - 15}{65 - 50} = 1.5 \text{ m s}^{-2}$$

$$F_{\text{net}} = ma = 32\,000 \times 1.5 = 48\,000 \text{ N}$$

$$F_{\text{net}} = F_{\text{driving}} - F_{\text{resistive}}$$

$$48\,000 = 61\,300 - F_{\text{resistive}}$$

$$\therefore F_{\text{resistive}} = 61\,300 - 48\,000 = 13\,300 \text{ N or } 13.3 \text{ kN}$$

Q28 continued

d What was the bus's average speed for the 150 s journey as shown by the graph? (5 marks)

d The bus's average speed will be equal to distance it covers over time. The distance covered is equal to the area under the graph.

$$\begin{aligned}\text{area} &= \left(\frac{1}{2} \times 10 \times 15\right) + (40 \times 15) + \left(\frac{1}{2} \times 15 \times 15\right) + (25 \times 0) + \left(\frac{1}{2} \times 10 \times 10\right) + (25 \times 10) \\ &\quad + \left(\frac{1}{2} \times 15 \times 10\right) + (10 \times 0) \\ &= 75 + 600 + 112.5 + 0 + 50 + 250 + 75 + 0 = 1162.5 \text{ m}\end{aligned}$$

$$\text{Average speed} = \frac{1162.5}{150} = 7.75 \text{ m s}^{-1}$$

Q29

(4 marks)

Blu-ray DVD players use a laser that emits a coherent beam of blue light that has a wavelength of 405 nm (405×10^{-9} m).

a Calculate the frequency of the blue laser light if the speed of light is 3×10^8 m s⁻¹. (2 marks)

$$\begin{aligned} \mathbf{a} \quad c &= f\lambda \rightarrow f = \frac{c}{\lambda} \\ f &= \frac{3.00 \times 10^8}{405 \times 10^{-9}} = 7.41 \times 10^{14} \text{ Hz} \end{aligned}$$

b Calculate the period of the blue laser light

(2 marks)

$$\mathbf{b} \quad T = \frac{1}{f} = \frac{1}{7.41 \times 10^{14}} = 1.35 \times 10^{-15} \text{ s}$$

Q30

- The following diagram shows a wave 1.0 s after it has been produced.

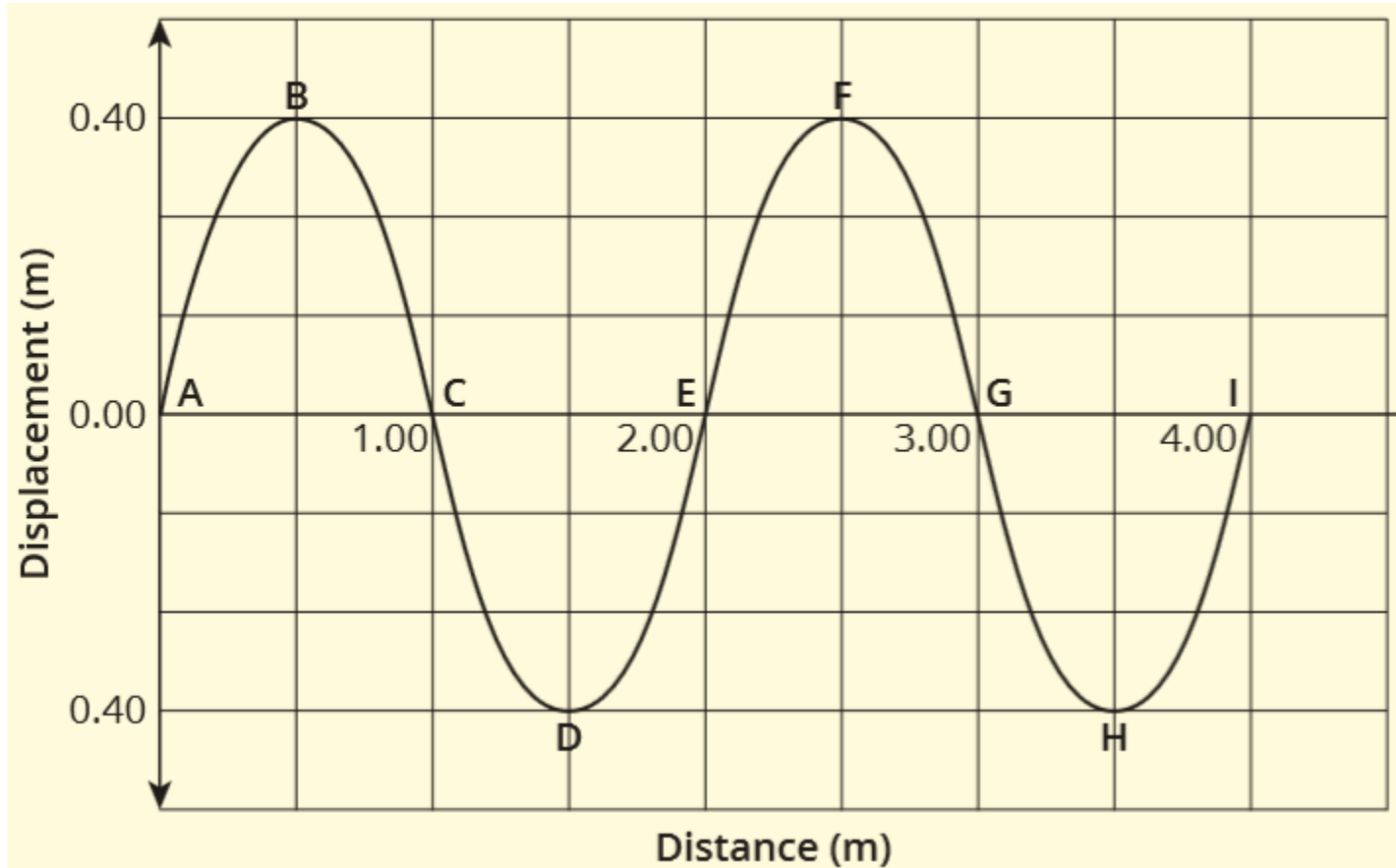

Q30 continued

a What is the amplitude of the wave? (1 mark)

a acceleration = gradient of the v - t graph at $t = 60$ s

$$\text{gradient} = \frac{\text{rise}}{\text{run}} = \frac{0 - 15}{65 - 50} = -1.0 \text{ m s}^{-2}$$

$$\therefore \text{acceleration} = -1.0 \text{ m s}^{-2}$$

b How many wavelengths are there in the diagram? (1 mark)

b $F_{\text{net}} = 0$ (constant velocity means $a = 0$ and $F_{\text{net}} = ma$)

c If the driving force provided by the bus's engine during the first 10 s of the journey was a constant 61.3 kN, what average resistive force acted against the bus during this time? (4 marks)

c acceleration = gradient between $t = 0$ and $t = 10$ s

$$\text{gradient} = \frac{\text{rise}}{\text{run}} = \frac{0 - 15}{65 - 50} = 1.5 \text{ m s}^{-2}$$

$$F_{\text{net}} = ma = 32\,000 \times 1.5 = 48\,000 \text{ N}$$

$$F_{\text{net}} = F_{\text{driving}} - F_{\text{resistive}}$$

$$48\,000 = 61\,300 - F_{\text{resistive}}$$

$$\therefore F_{\text{resistive}} = 61\,300 - 48\,000 = 13\,300 \text{ N or } 13.3 \text{ kN}$$

Q 30 continued

d What was the bus's average speed for the 150 s journey as shown by the graph? (5 marks)

d The bus's average speed will be equal to distance it covers over time. The distance covered is equal to the area under the graph.

$$\text{area} = \left(\frac{1}{2} \times 10 \times 15\right) + (40 \times 15) + \left(\frac{1}{2} \times 15 \times 15\right) + (25 \times 0) + \left(\frac{1}{2} \times 10 \times 10\right) + (25 \times 10) \\ + \left(\frac{1}{2} \times 15 \times 10\right) + (10 \times 0)$$

$$= 75 + 600 + 112.5 + 0 + 50 + 250 + 75 + 0 = 1162.5 \text{ m}$$

$$\text{Average speed} = \frac{1162.5}{150} = 7.75 \text{ m s}^{-1}$$

Q31

(8 marks)

On 20 August 1977 the unmanned space probe *Voyager 2* (see below), was launched. Since its launch it has visited all four of the outer planets—Jupiter in 1979, Saturn in 1981, Uranus in 1986 and Neptune in 1989. As of October 2017, it was about 17.3 billion kilometres from the Sun and heading out of the solar system.



To operate its electronic instruments and be able to send radio signals back to the Earth, *Voyager 2* was equipped with a radioisotope thermoelectric generator (RTG). RTGs use the heat generated from radioactive decay to produce electricity.

The radioisotope chosen for *Voyager 2*'s RTG needed to:

- be strongly ionising in order to release enough energy to generate the power needed by the probe's electronic instruments and radio
- be easily shielded so that any emitted radiation would not damage the probe's sensitive electronic instruments
- have a working lifetime of 35 years. To achieve this, its activity cannot drop below 40% of its initial activity in that time.

The following table is a list of five possible radioisotopes that could be used for *Voyager 2*'s RTG, and the daughter radioisotopes resulting from their initial decay.

Q31 continued

Parent radioisotope	$^{108}_{47}\text{Ag}$	$^{63}_{28}\text{Ni}$	$^{137}_{55}\text{Cs}$	$^{238}_{94}\text{Pu}$	$^{250}_{98}\text{Cf}$
Type of radiation emitted	γ	β	β, γ	α	α
Energy released per decay (eV)	720×10^3	70×10^3	510×10^3	5.59×10^6	6.13×10^6
Half-life (years)	418	100	30.2	88	13.1
Daughter radioisotope	$^{108}_{47}\text{Ag}$	$^{63}_{29}\text{Cu}$	$^{137}_{56}\text{Ba}$	$^{234}_{92}\text{U}$	$^{246}_{96}\text{Cm}$
Type of radiation emitted	none	none	γ	α	α
Energy released per decay (eV)	-	-	660×10^3	4.86×10^6	5.48×10^6
Half-life	-	-	2.6 mins	2.46×10^5 years	4.70×10^3 years

Which of the five radioisotopes would be the most suitable for *Voyager 2*'s RTG? Explain your reasoning, and why the other radioisotopes are unsuitable. Where necessary you should support your answer with appropriate calculations.

Q31 continued

a Ionising ability:

(2 marks)

b Shielding:

(2 marks)

c Working lifetime:

(3 marks)

Q31 continued

a Ionising ability

The chosen radioisotope needs to be strongly ionising. Of the radiation types emitted by the parent radioisotopes, alpha particles are the most strongly ionising.

Based on this criterion, Pu-238 and Cf-250 are the most appropriate choice of radioisotope for the RTG. Their daughter isotopes are also emitters of alpha particles.

b Shielding

To protect *Voyager 2*'s instruments the emitted radiation has to be prevented from reaching the RTG. Gamma rays are the most penetrating type of radiation and are difficult to shield against. This means that Ag-108 and Cs-137 are unsuitable because the gamma rays they emit, and in Cs-137's case those emitted by its daughter isotope, will damage *Voyager 2*'s instruments over time.

c Working lifetime

(Note: students have already ruled out Ag-108 and Cs-137 from part (b) above and narrowed it down to Pu-238 and Cf-250 from part (a) so not all data needs to be calculated as shown below).

Ag-108	Ni-63	Cs-137	Pu-238	Cf-250
$t_{1/2} = 418$ years	$t_{1/2} = 100$ years	$t_{1/2} = 30.2$ years	$t_{1/2} = 88$ years	$t_{1/2} = 13.1$ years
$t = 35$ years	$t = 35$ years	$t = 35$ years	$t = 35$ years	$t = 35$ years
$A = A_0 (1/2)^n$	$A = A_0 (1/2)^n$	$A = A_0 (1/2)^n$	$A = A_0 (1/2)^n$	$A = A_0 (1/2)^n$
$A = 100 (1/2)^{35/418}$	$A = 100 (1/2)^{35/100}$	$A = 100 (1/2)^{35/30.2}$	$A = 100 (1/2)^{35/88}$	$A = 100 (1/2)^{35/13.1}$
$A = 94\% > 40\%$	$A = 78\% > 40\%$	$A = 45\% > 40\%$	$A = 76\% > 40\%$	$A = 17\% < 40\%$
\therefore Ag-108 has a suitable working life	\therefore Ni-63 has a suitable working life	\therefore Cs-137 has a suitable working life	\therefore Pu-238 has a suitable working life	\therefore Cf-250 does not have a suitable working life

d The only radioisotope that satisfies all three criteria is Pu-238.

Q32

(11 marks)

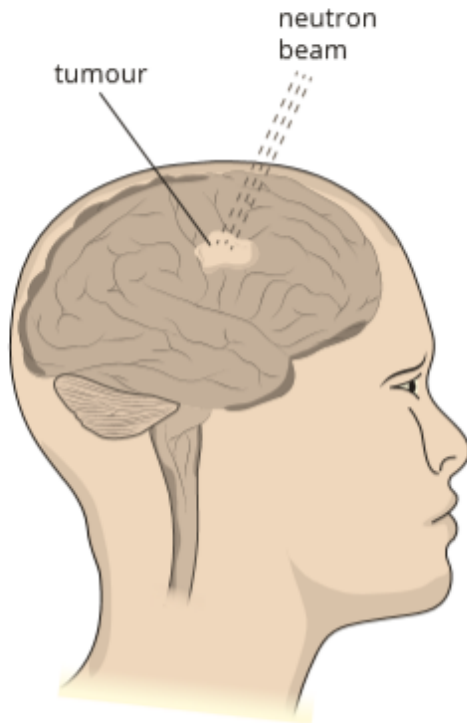

Boron Neutron Capture Therapy (BNCT) is a specialised form of radiotherapy that provides a way of destroying the cancer cells in a tumour without injuring adjacent normal cells. The process involves injecting the patient with the non-radioactive isotope boron-10. The cancer cells in the tumour take up the boron-10 and the patient's tumour is then irradiated with a beam of slow-moving neutrons, as shown in the diagram. The slow-moving neutrons are strongly absorbed by the boron-10 atoms, which will then decay by emitting alpha particles with an average kinetic energy of 1.47 MeV. The daughter isotope created typically has 0.84 MeV of kinetic energy.

Q32 continued

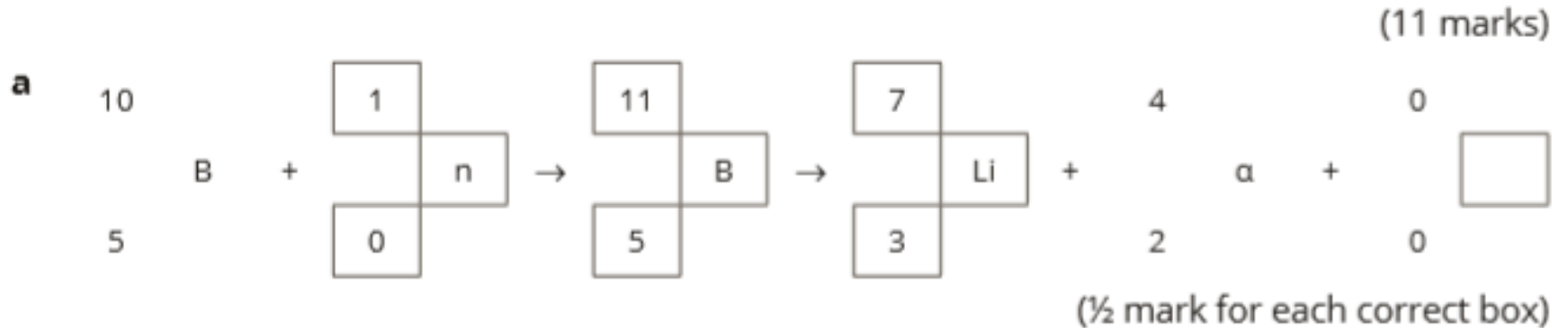

b absorbed dose = $\frac{\text{energy (J)}}{\text{mass (kg)}}$
 $= \frac{0.50}{0.070} = 7.1 \text{ Gy}$

c dose equivalent = absorbed dose × quality factor

QF of alpha particles = 20

dose equivalent = $7.1 \times 20 = 143 \text{ Sv}$

d The energy of the emitted alpha particles and the Li-7 daughter isotope is enough to ionise other atoms in the tumour, or to break the bonds between atoms. If this were to occur a sufficient number of times within a cancer cell it would die.